

Good Practice in Health Care

The Male External Catheter

Condom Catheter
Urinary Sheath

2008



ean

European
Association
of Urology
Nurses

Good Practice in Health Care

The Male External Catheter

Condom Catheter
Urinary Sheath

V. Geng
E. Bonns
P. Eelen
C. Seidler
H. Cobussen-Boekhorst

Table of Contents

page

Introduction	5
1. The male external catheter	6
1.1 Indications for male external catheters	6
1.2 Advantages	7
1.3 Disadvantages and considerations	7
1.3.1 Irritation	7
1.3.2 Immediate hypersensitivity	7
1.3.3 Delayed hypersensitivity	8
2. Products and materials	9
2.1 Types of male external catheter	9
2.1.1 Adhesives	10
2.1.2 External fixatives	12
2.1.3 Materials	12
2.1.4 Measuring	13
2.2 Urinary bags and collecting systems	14
2.3 Skin care products	16
3. Procedure	17
3.1 Assessment	17
3.1.1 Issues to be considered before fitting a male external catheter	17
3.2 Patient preparation	18
3.3 Application of the male external catheter	19
3.3.1 General aspects	19
3.3.2 Preparation in details	19
3.3.3 Applying adhesives	20
3.3.4 After male external catheter is applied	22
3.4 Removing the male external catheter	23
4. Complications & problems	24
4.1 Before application	24
4.1.1 Retracted penis	24
4.1.2 Risks	24
4.1.3 In combination with intermittent catheterisation	24
4.2 After application	25
4.2.1 Pressure sore	25
4.2.2 Skin lesions/allergies	25
4.2.3 Leakage	25
4.2.4 Urinary Tract Infections (UTIs)	25

continued ➤

5. Proactive and preventive care	27
5.1 Patients with reduced or no skin sensation	27
5.2 Hand hygiene	27
5.3 Promoting fluid intake	27
6. Summary	28
7. Conclusions	30
8. Key points	30
9. Abbreviations	30
10. References	31
11. About the authors	34

Introduction

The European Association of Urology Nurses

The foundation of the European Association of Urology Nurses (EAUN) is a direct result of the first nursing conference, organised at the XVth Congress of the European Association of Urology in Brussels, April 2000. The EAUN as an organisation receives administrative and financial support from the European Association of Urology.

The aims and objectives of the EAUN are:

- To act as the representative body for European nurses in urology and facilitate the continued development of urological nursing in all its aspects.
- To foster the highest standards of urological nursing care throughout Europe.
- To encourage urological research undertaken by nurses and enable the broadcasting of its results.
- To promote the exchange of experience and good practice between its members.
- To establish standards for training and practice for European urological nurses.
- To contribute to the determination of European urological health care policies.

Healthcare is not bound by geographical boundaries and the role of the nurse should reflect a sound knowledge and skills base across all European countries. The development of this booklet on male external catheters aims to support the skilled healthcare professional in Europe with the theoretical and procedural evidence required to support their practice, and to ensure patient safety, dignity and comfort.

Male external catheters are well known in the field of neurological and geriatric nursing, but the knowledge about them varies greatly from region to region, and there may be even more patients who could benefit from its use.

The aim of this booklet is to expand the knowledge regarding male external catheters and provide practical help in using them. The intention was to create an evidence-based guideline. However there is not enough evidence from the literature on this subject. In researching material for this booklet, the working group found limited information on the topic in national and international journals. Of the literature reviewed, there were only three clinical randomised trials, which were published in 1976, 1979 and 2006 with the topics condom catheter and urinary tract infections. Most articles reported only individual case reports or protocols. This booklet is developed through a consensus process by many nurses in various fields.

This document should be used to support those practitioners who have been assessed in practice as competent in this procedure. To support safe, effective practice, it is vital that appropriate education and training is provided to ensure the practitioner has a clear understanding of the normal urethral anatomy, and the potential problems and complications that may be encountered.

This document is intended to support good clinical practice and should only be used in conjunction with local policies and protocols.

1. The male external catheter

The male external catheter (MEC) is an external catheter used for the treatment of urine incontinence in men. This external catheter is not a true catheter, as it is not inserted into the body cavity duct or vessel.

The male external catheter is a simple rubber or synthetic sheath that is placed over the penis, in the same way as a condom used for contraception. Unlike a normal condom, a male external catheter has a plug to which a drainage tube is attached that allows the urine to pass into a urinary storage bag fastened around the leg. Also unlike a normal condom, most male external catheters are self-adhesive. The male external catheter is a non-invasive device, as it makes no contact with the mucosa of the urethra (1,2). Male external catheters can be used to manage incontinence that is resistant to management by other methods.

The male external catheter is also known as a: condom catheter, urisheath, condom drainage system, penile sheath, external catheter, urinary collection device, condom urinal, body worn urinal, and even a slang term, *Texas Condom* (33). In this booklet we consistently use the term male external catheter (or MEC) because it is the most commonly used name for this type of catheter.

Finally something about quality of life: the male external catheter can give men who suffer from incontinence greater confidence and comfort for this embarrassing problem.

1.1 Indications for male external catheters

Urinary incontinence can have a significant detrimental effect on a person's body image and self-esteem because it undermines society's norms relating to body control. This can be further complicated by the use of devices to control urinary incontinence. Sheath drainage systems are a discreet, reliable system that can have both physical and psychological benefits. A full continence assessment is paramount for a successful outcome as there are several potential problems associated with this method of management. There are a variety of products available, for the management of urinary incontinence, so the health professional needs a comprehensive knowledge of both products and application techniques (2,32).

- *Indication*

1. Overactive bladder incontinence without post void residual urine (PVR) in men
2. Incontinence in men - day and/or night loss of urine with or without urge, but without PVR
3. Urological problems in men with some neuromuscular syndromes
4. Complex orthopaedic surgery of the pelvis in men with a normal voiding pattern

- *Contraindication*

1. Significant post void residual urine
2. Complete acontractability (areflexia)
3. Sphincter dyssynergia with a significant retention of urine
4. Obstructive urological disease (13).

1.2 Advantages

Male external catheters offer the advantage of diverting the urine to a bag, thus decreasing urine odour and protecting the skin from contact with urine.

Male external catheters may reduce the risk of complications associated with navigating the barrier protecting the urinary tract from stool. This may be especially true in the presence of liquid stool (26,41). Some types of male external catheters might be able to reduce urinary tract infections compared to indwelling catheters in hospitalised patients, but more research is needed (21,22,23,24,25,36).

1.3 Disadvantages and considerations

The most common disadvantage with male external catheters appears to be failure to stay in place due to incorrect sizing and placement. However, there are other issues nurses must take into consideration, primarily, possible skin reactions (11,12,13,29,40).

One- and two-piece male external catheters are manufactured in a range of materials including latex and silicone. Some patients may have allergic reactions to these materials (7). It may be advisable to perform a patch test on a sensitive area of the skin, such as the forearm, to assess any potential allergic reaction (34). Patients must be advised of allergies or skin reactions, and given instructions to follow if this happens, i.e. removing the male external catheter immediately and contacting their clinician.

There are three distinct types of reaction that may occur with the use of male external catheters: irritation, immediate hypersensitivity, and delayed hypersensitivity (2,3).

1.3.1 Irritation

Irritation is a non-allergic reaction that tends to happen almost immediately after the male external catheter has been applied or up to several hours later (30). It is recognised as pink or red discolouration of the skin where the sheath or adhesive comes in contact with the skin. Nurses must inform caregivers and patients who may not be accustomed to this type of product that this may be a possibility. They should be advised to remove the male external catheter immediately if this occurs and gently wash and thoroughly dry the area to remove any residual adhesive. This type of male external catheter should not be applied again and the incident should be reported to the clinician. The reaction should be recorded in the patient's records, so that the same product is not used again (30).

1.3.2 Immediate hypersensitivity

Recognised by the Medical Devices Agency (1996) (3) this reaction is usually a response to a naturally-occurring protein in rubber latex and will occur approximately 5–30 minutes after the patient is exposed to a latex male external catheter. The reaction is more pronounced than irritation and the skin appears more reddened or inflamed. The skin may also take on a smooth stretched appearance. The reaction subsides quickly when the male external catheter is removed. There may be some localised residual skin irritation and oedema, which can take 3–24 hours to resolve, depending on the health of the patient (30).

1.3.3 *Delayed hypersensitivity*

Delayed hypersensitivity has been recognised as a problem for some patients (30). This is also known as contact dermatitis and can occur up to 48 hours after the initial application of the male external catheter. It generally results in the formation of blisters or papules and usually subsides after several days but can cause considerable discomfort to the patient. Nurses and caregivers should be made aware of the possibility of this happening and instruct patients and caregivers on treatment. The male external catheter should be removed and the affected area should be washed to remove any residue. The area should be dried and may be left open to the air unless blisters have formed and have exuded fluid. A clean non-occlusive dressing may be placed over the affected area (30).

Although hypersensitivity reactions are not common, it is important to be aware that edema of the penis can cause problems with bladder drainage due to pressure on the urethra. In the event of a hypersensitive reaction, it is also important that this is appropriately noted.

2. Products and materials

2.1 Types of male external catheters (4,31)

The main differences between male external catheters are the materials, shapes and adhesives. The male external catheter can also be a one or two-piece unit. The two-piece units consist of one part which remains on the penis and a removable drainage tip. Some male external catheters also contain an anti-reflux valve to prevent urine backflow and leakage.



Fig. 1. One-piece catheter



Fig. 2. Two-piece catheter



Fig. 3. Male external catheter with an anti-reflux valve



Fig. 4. Male external catheter with balloon principle



Fig. 5. Male external catheter with a help stripe

There are also special kinds of male external catheters, which are niche products. Here are four examples:

- **Drip urinal:** This consists of a tubular sleeve, which encompasses the penis at one end and a hose-fitting outlet at the other end. The hose-fitting outlet can be attached to a waist bag reservoir or a drip bag. The outlet can be drained by means of a tap. Some drip urinals allow for connection of multiple drainage bags in order to decrease reservoir emptying (34).



Fig. 6. Drip urinal

- **Pubic pressure urinal:** These urinals are designed for use by men who find the traditional male external catheters unsuitable, if the sheath is not successful. e.g. retracted penis or if there are irritants in the urine (by chemotherapy for example). Of all the body worn appliances, the pubic pressure urinal is generally recognised as the most successful design. The urinal is held close to the body by waist and groin straps. This pressure allows the penis to protrude into the urinal.
- **Penis and scrotum urinal:** These urinals are designed to contain the whole genitalia. These can also be used by men with a retracted penis.
- **Male external device:** This device is placed on the foreskin and can be used by men with a retracted penis.

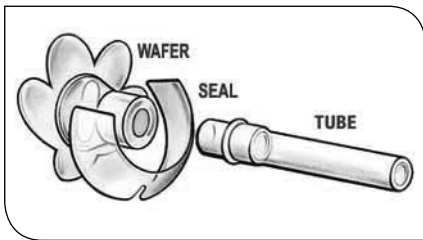

Fig. 7. Male external device



Fig. 8. Male external device

2.1.1 Adhesives

There are different types of adhesives that are used to attach male external catheters to the penis:

- **Self-adhesive male external catheters:** The ready to use condom has a sticky film on its inner surface which attaches the male external catheter to the penis. The male external catheter can be rolled up and fixed in place.

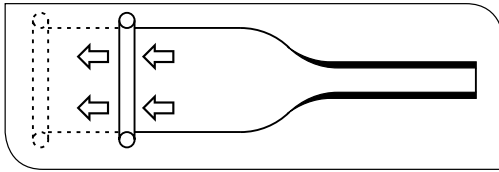

Fig. 9. & 10. Self-adhesive male external catheter

- Skin adhesives: There are non-self adhesive male external catheters which do not contain an adhesive film so they require an application of a type of skin glue onto the skin before rolling the male external catheter over the penis.

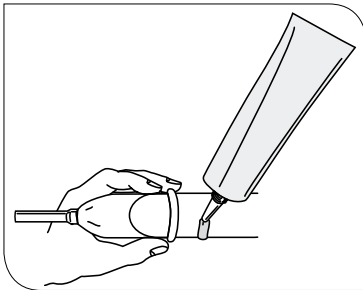

Fig. 11. Skin glue

- Adhesive strips: These male external catheters require an adhesive strip to attach the male external catheter to the penis. The adhesive strips are placed onto the penis (encircling it) and the male external catheter is rolled over the penis attaching to the adhesive strips.

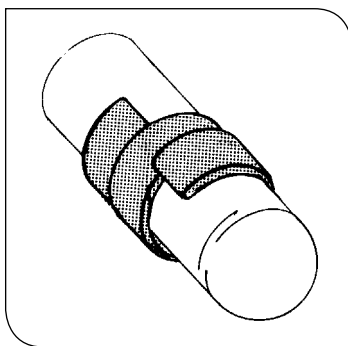
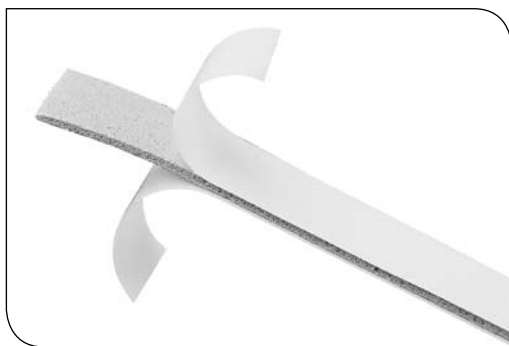

Fig. 12. & 13. Adhesive strips

2.1.2 External fixatives

Reusable foam and elastic strips, secured by Velcro, are available.

Securing a sheath to the penis without using any adhesives will generally result in a less secure fixation. However, some men prefer this method- especially in cases where the catheter is removed and replaced frequently (35). Using external fixatives may be associated with an increased risk of penile strangulation.

2.1.3 Materials

- Latex: a natural product which is very soft and flexible. Unfortunately, some patients may have latex sensitivities and develop an allergic reaction. For this reason, in a number of European countries (for instance Great Britain and the Netherlands) the use of latex products in the medical environment is currently slowly being phased out, also since there are a number of alternative (latex-free) products available.
- Silicon: a translucent and breathable material that is very bio-compatible. Allergic reactions are rare. Its “skin-friendliness” can be considered its highest advantage. In addition the translucent material provides a view of the skin in order to recognise any irritation or emerging skin problem.
- Poly vinyl chloride (PVC): a synthetic and resistant material, which may be exposed to sunlight, urine and mechanical impact. The production of PVC, however, requires the incorporation of plasticisers. Such softeners may have a bio-hazardous effect on long-term users, which should be taken into consideration when deciding to use PVC products for a longer period.
- Polyurethane (PU): a synthetic material just like PVC. Many latex free male external catheters are made from PU. PU male external catheters are thinner than other male external catheters. This results in improved wear comfort compared to other materials due to the properties of the PU. Some types of PU may cause allergic skin reactions. However, these PU types are not usually used in male external catheters.

2.1.4 Measuring

In order to find the appropriate size for a male external catheter, the circumference of the penis needs to be measured. The penis should be measured at the shaft where its diameter is largest in order to assess the correct size (42). For measuring, the patient should be seated on the edge of a bed or chair with the legs slightly spread. In this free position both scrotum and penis are in their natural anatomic orientation and can best be measured.

The actual male external catheter size of the penis may be hard to determine if it ranges between two sizes. Should this situation occur, the smaller size of the two should be selected. Male external catheter materials are sufficiently flexible and allow the penis a snug but not tight fit. Choosing the larger of two sizes might result in urinary leakage.

Many manufacturers and suppliers of male external catheters offer sizing guides (for example cardboard moulds or patterns), to help determine the size that will ensure safe and comfortable wear (33,35). It is important to note that manufacture sizes may vary, and sizing guides provided by one manufacturer should not be used for another.

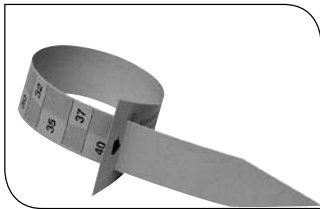

Fig 14. Measuring device



Fig 15. & 16. Two other measuring devices

Listed below are various size ranges provided by three manufacturers:

- Coloplast
21, 25, 30, 35, 40 mm
- Hollister Incorporated
25, 29, 32, 36, 41 mm
- Sauer Continence
18, 20, 22, 24, 26, 28, 30, 32, 35, 37, 40 mm

It is more important to determine the exact diameter of the penis to fit the correct size of the male external catheter than the length of the penis. All condoms currently available will fit most penis lengths, except when the penis is very small or retracted.

2.2 Urinary bags and collecting systems

The choice of drainage bag is dictated by several factors:

- Reason for use
- Intended duration
- Patient mobility
- Patient choice

Consideration should be given to the following:

- *Bag capacity and placement*

Either leg or bed bags can be used. There are three common sizes of leg bags: 350ml, 500 ml and 750ml. A patient might use a smaller bag to be used during the day and a larger one (1500 - 2000ml) at night.

The leg bag needs to be attached properly, in order to allow urine to flow into the bag without difficulty. The leg bag can be placed at different positions on the leg: thigh, knee (special bag needed), under the knee. A bed bag can be used in place of a leg bag and needs to be placed below the person to permit the flow of urine. It is important to choose the drainage bag that best meets the needs of the patient best.



Fig. 17. & 18. Leg bags for walkers and wheelchair users

A leg bag is the best choice for ambulatory patients. The bag is most commonly fastened around the thigh or calf with two straps. Sleeves and belts hold the bag safely and may be more comfortable.

When the urine bag fills it becomes heavier and may stretch the straps. The urine bag should not be allowed to fill to the point of discomfort, but be emptied when $\frac{2}{3}$ full. It is recommended to change the urine bag at least once a week, but in many hospitals the bag is changed every time the male external catheter is changed. Changing the urinary bag should depend on local or national policies or standards.

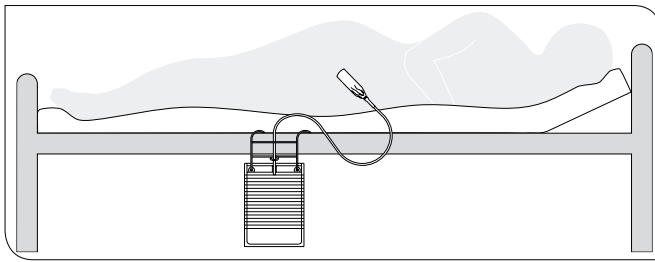

Fig. 19. Bed bag with male external catheter

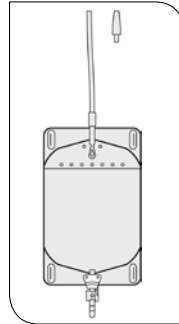
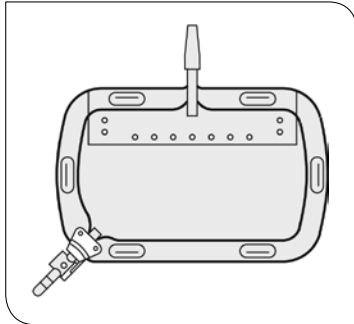

Fig. 20. & 21. Other legbags

- **Tubes and taps**

There are at least three different tube lengths, direct connection (without tube), 10 cm and 30 cm. (Some manufacturers may offer additional lengths.) Selection the correct length of the tube is necessary to prevent any twists that might result from coiled tubing.

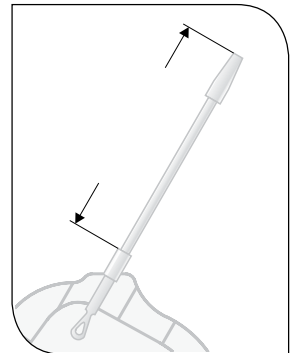

Fig. 22. Tube length

Choosing a tube to connect the urinary bag to the male external catheter is dependent on the radius of the tubes from the condom and the urinary bag. These connecting tubes (adapters) can be seen below.

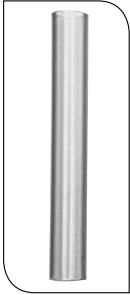

Fig. 23. Tube without adapter



Fig. 24. Smooth universal adapter



Fig. 25. Ridged universal adapter



Fig. 26. Swing tap



Fig. 27. Swing tap

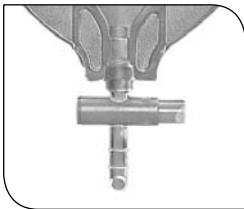

Fig. 28. Sliding tap

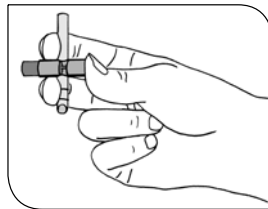

Fig. 29. Sliding tap



Fig. 30. Sliding tap

2.3 Skin care products

The skin should be dry and undamaged before placing the male external catheter onto the penis. If the skin is undamaged, a normal personal hygiene is sufficient. Different skin care products are available on the market to help keep the skin healthy.

A moisturising cream should be pH neutral, oil free, and unscented. It should be free of soap and other cosmetic ingredients. An oil based moisturising cream may change the integrity of the glue and affect the adhesive leading to leakage or displacement of the male external catheter. Perfume, soap or other cosmetic ingredients can irritate the skin, causing fungal skin infections, skin damage or abrasions and allergies.

3. Procedure

3.1 Assessment

All too often in the past male external catheters have been dismissed as having failed their user and care-giver simply because they have failed often due to being poorly fitted or incorrectly measured (11). Nurses need to be aware that there are many different sizes and lengths of male external catheters available to fit the majority of men, even those with penile retraction problems (11).

Assessing the needs and desires of clients regarding the choice of a satisfactory urinary drainage system can be quite time consuming. Yet the benefits derived from correct assessment and an effective drainage system is immeasurable. Along with the physical benefits, nurses must consider the psychological advantages such as patient motivation, dignity, independence and self-esteem, which are equally important. Patients who may be suitable for these systems need to be chosen carefully and it is important that the patient is well taught and instructed in the procedures about the male external catheter (12,6). Applying a male external catheter and attaching its associated leg bag is not an easy process and therefore requires practice. This is especially important when teaching clients how to apply and manage a male external catheter as inexperienced staff can reinforce negative information and practice in the client.

Therefore patients must ideally have either a considerable amount of finger-thumb dexterity, or a care-giver who will become involved in the fitting procedure. Male external catheter systems also demand attention on the part of the nurse to ensure that they fit appropriately and that there is no deterioration in skin condition.

Finally, it is really important to check the Post voided residue (PVR) and check the patient for any urinary tract infection (UTI).

Before prescribing a male external catheter to the incontinent patient, any infection must be treated and when a patient suffers from PVR the patients must be referred to the general practitioner for treatment.

3.1.1 *Issues to be considered before fitting a male external catheter (2,11).*

- Will the patient accept wearing a male external catheter and drainage bag?
- Does the patient have the hand dexterity to fit the male external catheter himself? If not, who is going to fit the male external catheter for the patient? Will the patient's attitude allow someone else to apply the male external catheter?
- Is the patient confused? (This may be a risk factor in that he may pull the male external catheter off, which would cause skin soreness or trauma.)
- Is the patient allergic to latex? (Non latex products need to be used)
- What is the degree of penile retraction, if any?
- Is the skin of the shaft of the penis intact? (Male external catheters should not be applied if the skin is broken or excoriated.)
- Check PVR.
- Check UTI.

Box 1. Points to remember when selecting and fitting a urinary sheath

It is important to:

- Measure correctly the length of the penis and its circumference at its widest point
- Test the product for sensitivity, bearing in mind the fact that some patients are allergic to latex
- Select a sheath that is easy to apply, as ease of application promotes confidence in users
- Ensure the urine bag is of the correct size and that it is well supported to avoid dragging on the sheath
- Adjust seating for wheelchair users, if necessary, to allow better drainage
- Monitor skin condition for soreness or ulceration
- Shorten pubic hair to prevent it being caught in the sheath. Do not shave the area if possible, as subsequent regrowth can cause irritation
- Avoid kinking or twisting of the sheath or the drainage bag as this allows urine to pool, thereby weakening the adhesive or blocking drainage completely
- Ensure products are easily available and on the *Drug Tariff*

Fig. 31. Points to remember when selecting and fitting a urinary sheath. Doherty, 2001 (2)

3.2 Patient preparation

Applying a male external catheter is a non-invasive procedure that can cause embarrassment, physical and psychological discomfort and impact negatively on the patient's self image. To ensure that the patient is fully prepared for the application it is the responsibility of the health care professional to inform the patient of the reasons and necessity for the procedure, and obtain the patient's permission (5,9).

In many countries and regions, patients are required to sign a consent form that indicates agreement for the practitioner to undertake a procedure. Informed consent also implies an understanding of the event and the associated potential complications/problems. It is not common practice within Europe for patients to provide written consent for male external catheter application, but it is however a necessity that verbal consent and agreement is reached and the relevant information recorded in the patients medical and/or nursing notes (10).

Explaining the procedure and providing the reason for this to the patient will help reduce patient anxiety and embarrassment as well as help the patient report any problems that may occur during and after the procedure. Relaxing the patient by offering reassurance and support will help for smoother placement of the male external catheter and assist in avoiding unnecessary discomfort.

3.3 Application of the male external catheter

3.3.1 *General aspects*

Hands must be cleansed immediately before each and every episode of direct patient contact or care and after any activity or contact that could potentially result in contamination. Hands should be cleaned preferably with an alcohol-based hand rub, unless hands are visibly soiled, in which case they should be cleaned with soap and water. Hands must be disinfected between caring for different patients or between different care activities for the same patient (19).

Gloves must be worn for invasive procedures, contact with sterile sites and broken skin or mucous membranes, and all activities that have been assessed as carrying a risk of exposure to blood, body fluids, secretions or excretions, or sharp or contaminated instruments. This is intended to protect the patient and the nurse. It is not easy to handle a male external catheter with gloves but it is possible.

Gloves must be worn as single-use items. They must be put on immediately before an episode of patient contact or treatment and removed as soon as the activity is completed. Gloves must be changed between caring for different patients and between multiple treatments done with the same patient.

Before applying a male external catheter, it is important that the right size is available (See Section 2.1.3). A urine collection device, generally a urine bag to connect to the condom is also needed (See Section 2.2) (1,6,8,33,34).

Since there are many types of male external catheters, it is strongly recommended to follow the manufacturer's instructions for application.

3.3.2 *Preparation in details*

1. Wash your hands before (and also after) the application.
2. Gather the equipment:
 - male external catheter
 - drainage bag (leg or bed) with tubing
 - water, soap, wash cloth, towel
 - clamp and scissors if needed
3. Wash the penis with soap and water. Rinse and dry. Do not use re-hydrating soap as it may cause the adhesive to fail. If that is the only cleanser available do not put on a new condom directly. Wait 5 to 10 minutes.
4. Trim the hair on the penis and its base so that the hair will not stick when the adhesive is applied (6). A protective cloth placed over the base of the penis can also assist in preventing hair from getting caught in the adhesive. Another tip to keep the hair out of the way and to get a clean dry field around base of penis is to tear a small hole in the centre of a paper towel and then slip this over the penis to the base (35).
5. Assess the penis for irritation or redness to determine if a male external catheter can safely be used.

6. Roll out the condom as specified by the manufacturer's instructions before rolling over the penis (29).

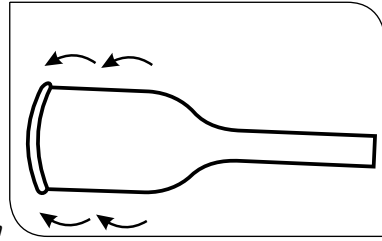

Fig. 32. Roll out the condom

7. Leave 2-3 cm space between the tip of the penis and the end of the male external catheter. More than 2-3 cm might promote catheter twisting and restrict the urine flow.
8. Wait for at least 15-20 minutes after a bath or shower before application.
9. Place the protective cloth over the pubic hair so that it does not get glued together and make the adhesion process more difficult.
10. It is preferable if the penis is erect but it is not absolutely necessary. If no erection is present, stretch the penis slightly by pulling.

3.3.3 Applying adhesives

Check patient's records for allergies. If there is a possibility that patient may be allergic to condom material or adhesive, do a skin test on a small area of skin before applying. (See section 2.1.1 for depictions of the adhesives.)

- *Self-adhesive condom*

1. Stretch the penis gently as you roll on the condom.
2. When the condom is unrolled, press it against the penis so it adheres. No other glue or adhesive strip is needed.

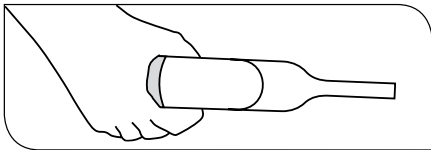

Fig. 33. Press the condom against the penis

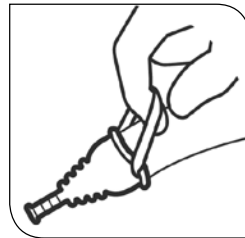

Fig. 34. Self adhesive condom with a help stripe to roll on the condom

- *Tape strip*

1. The tape strip is adhesive on both sides. A band of adhesive 2-3 cm wide is preferred.
2. Apply the adhesive double-sided tape in a spiral overlapping fashion around the base of the penis. Do not stretch the strip. Make sure it is not too tight.

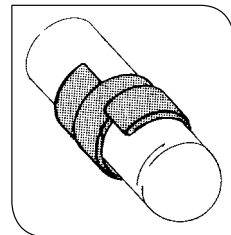

Fig. 35. Spiral overlapping of the tape stripe

Roll on the condom over the tape and press to attach.
(In case of hydro-colloid tape it is recommended to apply pressure with the hands for about 30 seconds, so that the warmth of the fingers increases the adhesive strength.)

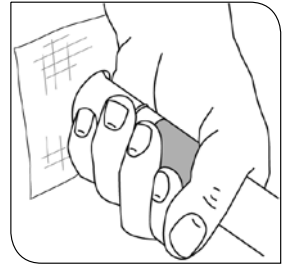

Fig. 36. Apply pressure on the condom

- *Liquid adhesive*

1. Apply the adhesive, in small quantities, in a ring on the middle of the penis shaft. Do not put adhesive on any skin defects. Spread the adhesive well and uniformly.
2. Unroll the condom over the adhesive. Do not wait too long before applying the condom or the glue may dry.
3. Press tightly on the condom.

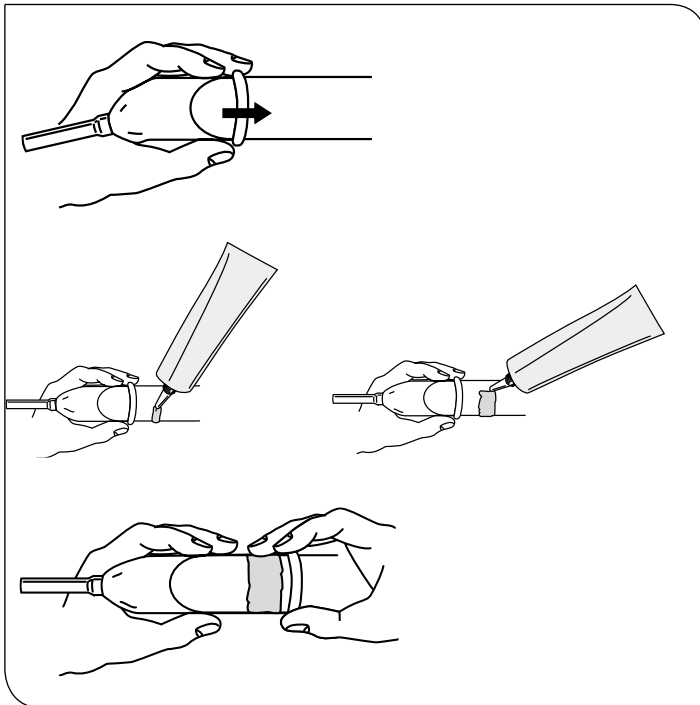

Fig. 37. Process of gluing with a liquid glue

- *Male external device*

Read the manufacturer’s instructions before applying the special male external device.

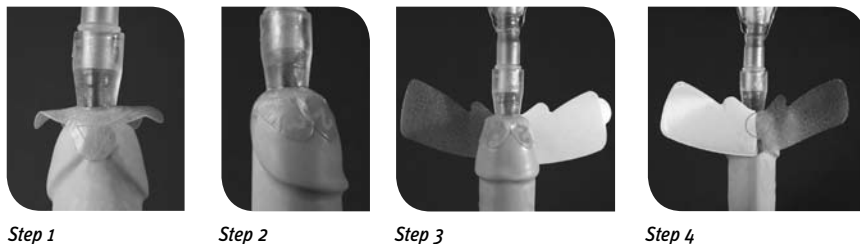

Fig. 38. Application in 4 steps

3.3.4 After male external catheter is applied

1. Connect the drainage bag with tube to the connector tip.

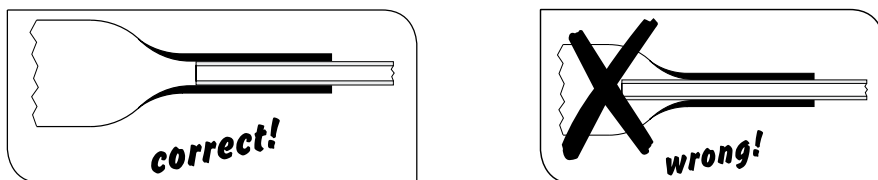

Fig. 39. Correct and wrong way to connect condom and connector tube

2. Make sure the system is free of twists and kinks. Attaching a leg bag, adjust the length of the inlet tube, before connecting the male external catheter to the leg bag. This helps prevent any twists.
3. Pay special attention to the foreskin of an uncircumcised male and make sure the foreskin is returned to its natural position. Failure to return the foreskin can lead to swelling and possible constriction.
4. Check for proper size and adhesion of the condom.
5. If necessary, to avoid pressure marks or if the penis retracts during micturition (emptying the bladder), the remaining rubber ring behind the adhering area can be removed by cutting or tearing the rim while the male external catheter remains adhered (33,34). Be careful that the skin is not hurt.

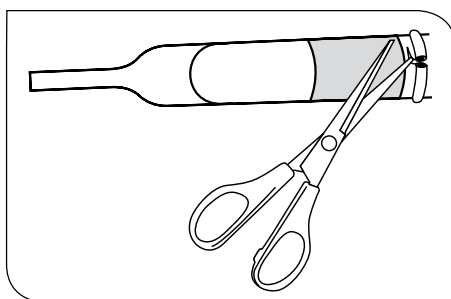

Fig. 40. Cut the rim

3.4 Removing the male external catheter

Remove the male external catheter and the tape simply by rolling them off.

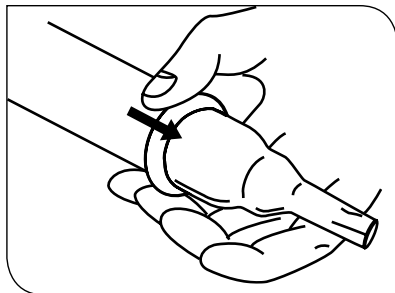

Fig. 41. Condom roll off

Usually, the adhesive comes off with the male external catheter when removed. However, if there is adhesive remaining it can be washed with skin care products or rubbed off. Do not remove the adhesive with solvents, such as acetone or similar substances, since this will disrupt the natural oil balance of the skin and may cause chapping and cracking, leading to inflammation. Non solvent based adhesive remover pads are available and recommended. Also products from the stoma care could be used (33,34,35).

Note: Male external catheters must be changed at least every 24 hours, i.e. once a day, unless otherwise specified by the manufacturer's instructions.

4. Complications & problems

4.1 Before application

4.1.1 *Retracted penis*

Penile retraction occurs when the penis retreats inside the prepubic fat. This is a common occurrence in older men. If there is some penile retraction, the patient may be able to use a shorter length male external catheter. If total penile retraction is observed when the patient is sitting down, neither a standard nor short length male external catheter may stay in place and will fall off (11).

- *Assessing penile retraction*

Have the patient stand (if possible) and observe penile length. Gently press back on either side of the penis towards the pubic area to expose as much retracted length of the penis as possible. Observe the change in length and position. If the seated penis length is less than 5 cm, use a shorter length male external catheter (2,11).

Special male external catheters are available on the market for patients with a shorter or retracted penis. Since a retracted male external catheter is shorter in length than a regular male external catheter, there is less area for the adhesive side of the catheter. Therefore it is most important that the correct male external catheter size is selected. To apply the male external catheter, the patient should lie on his back. (Sometimes placing a pillow underneath the hips is helpful.) In this position, it is easier to reach most of the penis to attach the male external catheter. In cases of a retracted penis it sometimes helps if the penis is somewhat erect. The patient can do this at home if still possible. When the male external catheter is placed in a proper way, the male external catheter can “handle” a retraction of the penis better (2,11).

A redundant or hyper mobile prepuce may result in the male external catheter not staying in place. In case of long-term male external catheter use, after consultation with a doctor and the patient, circumcision may be a consideration.

4.1.2 *Risks*

Although male external catheters are less invasive, their usage is not without risk. Explicit if there is a wrong handling (e.g. wrong size of the male external catheter). Skin necrosis, penile strangulation and urethrocutaneous fistula have been reported (12,13). Proper sizing of the male external catheter and careful application to prevent rolling or wrinkling may prevent such events (13).

4.1.3 *In combination with intermittent catheterisation*

For people who have to use male external catheter and also practice the intermittent catheterisation (IC) there is a special system which allows for repeated IC without disturbing the adhesive area of the male external catheter. For these users, it will be better to use male external catheters with a removable tip. The tip can be replaced after intermittent catheterisation, using one male external catheter per day (34). Beware, the detachable tip is stiff and can cause damage of the skin in patients with diminished or no skin sensation. The system is only available with latex condoms however the issue of latex hypersensitivity must be carefully considered. The system is a good but temporary solution.

Another solution: use a normal condom and cut off the condom just before the meatus, catheterise and put on a new male external catheter over the old one. In this case the skin is protected and the male external catheter must not be removed for every catheterisation. Pay attention that the condom over the condom is not too tight.

When the patient is suffering from incontinence between intermittent catheterisation, he has to contact his general practitioner or urologist, so he can check for any UTI and start with appropriate medications (e.g. antibiotics, anticholinergics or botulinum toxin).

4.2 After application

4.2.1 Pressure sore

If the male external catheter is removed and there are signs of a pressure sore or skin lesion, the size and the adhesive procedure should be evaluated.

4.2.2 Skin lesions/allergies

The male external catheter can adhere to small wounds or skin lesions if applied over a protective dressing. A hydro-colloid dressing will not interfere with the action of the adhesive.

4.2.3 Leakage

If a male external catheter does not remain secure for a 24 hr period the likelihood is that:

- stronger adhesive is needed
- male external catheter is too large
- penile retraction is present
- UTI
- Aggressive urinary output (occurs in cases of UTI and chemotherapy)
- combination of the problems mentioned above

- *Leakage prevention*

In the event of a large volume urine loss a male external catheter containing an anti-reflux membrane can be useful in maintaining the integrity of the adhesive and protecting against leakage.

Note: A urine sample can be taken when the male external catheter is being changed:

- Remove the condom
- Retract the foreskin and clean the glans penis
- Allow the urine to collect in sterile container

4.2.4 Urinary Tract Infections (UTIs)

Some considerations:

In patients with spinal cord injuries, a seven-fold reduction in the incidence of UTIs was observed when urinary sheaths were used to manage continence problems as compared to patients using indwelling catheters (21).

It is quite likely that the use of male external catheters may reduce the risk of developing UTIs in patients suffering from fecal incontinence due to the presence of a mechanical barrier protecting the urinary tract from stool. This effect may even be more pronounced in the presence of liquid stool (21).

Waites et al (1993) (27) have shown in their study that less-than daily male external catheter replacement correlates with an increased risk for UTI; a finding confirmed by Zimakoff et al in 1996 (23).

In general, patients managed by male external catheters are at increased risk of developing UTIs (see below refs). There is also a direct correlation between UTIs, the use of diapers and indwelling catheters (24).

However, male external catheters are less likely to induce bacteriuria, symptomatic UTIs or death than indwelling catheters. This difference is most pronounced in men without dementia (25).

A study by Ouslander (1987) (26), evaluating the relative frequency of UTIs in men with and without external catheter, showed that the risk for developing UTIs was significantly higher in the group managed with an external catheter than in the continent or incontinent group without an external catheter.

One has to keep in mind that UTIs are a prevalent problem and there is a distinct relation to incontinence care. But, incontinence is also a separate pathology where a decision has to be reached as to which problem has preference; what should be treated first? It is very important to fully inform patients about what problems may be encountered related to the use of male external catheters so that the patient can reach a sound decision.

5. Proactive and preventive care

5.1 Patients with reduced or no skin sensation

Patients with sensation problems need to follow the same instructions and advice given to all users. However, there are additional items that need to be considered.

It is essential to choose a male external catheter that the patient can handle independently (or as much as possible). Some of the male external catheters have features such as an enclosed applicator, peeling straps and accessories, which make them easier and more comfortable to use than others. However, the right choice is always individual and may vary with circumstances.

Patients with poor sensation must be even more careful to correctly assess and choose the correct male external catheter size. Since they have problems feeling pain (due to poor sensation) the user may not feel if the penis is too tightly squeezed or if skin inflammation or damage has occurred. Improperly fitting male external catheters may lead to these conditions.

Male external catheters made of harder/stiffer material may cause pressure ulcers and other skin damage. When changing the male external catheter, it is important to examine the skin covered by the male external catheter. Strangulation, inflammation and other discomfort may not be observed or reported by the patient.

5.2 Hand hygiene

The prevention of UTI is of primary importance in male external catheter care. Prevention can be aided by good hand washing and wearing gloves before and after any interaction with a catheter (14,19,35). Healthcare professionals also have a pivotal role in educating and disseminating good hand hygiene practice to patients.

5.3 Promoting fluid intake

'Good fluid intake' is associated with catheter care advice but until recently there has not been much evidence to support this information. Good fluid intake also dilutes urine and therefore can inhibit bacterial growth (15). It also ensures a constant downward drainage and flushing effect (16). Poor fluid intake can precipitate constipation, which can impede urinary drainage via a catheter by causing pressure, occlusion and kinking (17). Interestingly, the type of fluid consumed appears to be insignificant as long as the volume is sufficient to prevent the concentration of urine; however positive benefits have been attached to the drinking of cranberry juice, a topic which has also been the focus of some studies and advice over the last decade, with further information being required (18,38,39).

6. Summary

Monitor and note any difficulties that may occur when using male external catheters. If there are any problems, act according to local policy/protocol.

Identification and management of problems is essential when caring for patients with male external catheters and caregivers should be aware that:

- Ongoing reassurance throughout the procedure is essential.
- Antibiotics should not be given as a standard maintenance treatment.
- Cranberry juice may have a role in the prevention and management of bacteriuria.
- A diary can be useful to monitor problems, record interventions and evaluate care.

Problems	Possible reasons	Possible solutions
Pressure sore at the penis shaft	Condom is too small	Select a larger size condom
	Pressure from the rim is too strong	Cut the rim
	Pressure from the adhesive stripe/ tape is too strong	The adhesive stripe/ tape should not be glued circular but following a spiral pattern
Pressure sore at the foreskin	Pressure from the condom is too high due to e.g. an erection	Unroll the urinary sheath 4-6 cm to ensure that there is sufficient space between the foreskin and the tip of the condom
Leg bag drainage problems - disruption of urine flow	<ul style="list-style-type: none"> • The male external catheter is trapped beneath the elastic trim of the under garment • Clothing is too tight • The tube is too long or kinked • The leg bag is not secured properly • The leg bag is not positioned correctly • The leg bag contains air 	<ul style="list-style-type: none"> • Select more loose fitting clothes • Check the tube • Check the leg bag for security and position • Replace the drainage bag
	The urine is not clear	<ul style="list-style-type: none"> • Check for infection • Check fluid intake • Check PH of the urine
Leakage of the condom	Condom does not fit well	Measure again and select the correct size
	The adhesive glue is not sufficiently effective	<ul style="list-style-type: none"> • Use more adhesive glue • Use a different brand of adhesive
	The adhesive and the condom material are not compatible (glue does not stick to the catheter)	Use compatible material
	Technique to apply adhesive is incorrect	Practise technique on a model first
	Hairs may be caught between the condom and the skin - thereby producing small leakages	Remove the hair

Problems	Possible reasons	Possible solutions
The connecting tube keeps slipping away from the male external catheter	The connecting tube and the male external catheter are not compatible	Choose compatible materials Roll the connecting tube a little further over the tip of the condom for more security
Air in the urinary bag	Never allow air to enter the leg bag through the outlet tap	Always leave a small amount of urine in the bottom of the bag. This increases the suction in the system (creating a partial vacuum) which helps drainage and prevents build-up of urine in the buffer zone of the urinary sheath
Skin irritation or sores	Sensitivity / allergy for skin care products or material	Test an alternative product on a neutral area of skin; e.g. inside of the wrist, to ensure there is no allergic reaction
	Prolonged use of adhesives	Replace condom with one made of different material. Use a different brand of adhesive – before use, test on a neutral area of skin
	Talcum powder	Use condoms containing no talcum powder
Allergic skin reaction	Latex allergy	Use talcum powder free condoms as well as latex free condoms
Skin too damp	Condom was applied too soon after a bath or shower	Ideally, wait at least 15 minutes after a shower or a bath before applying the condom
Skin abrasions, fungal infections		Consult a doctor
Urinary tract infection	Optimal hygiene is of the utmost importance	Patient education, inform on the mechanism of UTI development and provide clear instructions on the hygienic aspects involved in using male external catheters
	Low fluid intake	Increase fluid intake
	Condom replacement interval is more than 24 hours	In case the catheter is not replaced within 24h, there is an increased risk of developing UTIs
Male external catheter does not stay in place	Redundant of hyper mobile prepuce	After consultation with a doctor and the patient, circumcision may be a consideration (will apply to long-term usage)

Fig. 42. Overview of possible problems and practical solutions

7. Conclusions

A male external catheter can offer a valuable alternative method to manage urinary incontinence in men. However, the male external catheter is probably the most under-valued aid in resolving problems associated with male urinary incontinence. Individual patients needs professional support to obtain the best results possible when using a male external catheter (33).

8. Key points

Key points on how to get the best results using a male external catheter:

- Carry out a health care and incontinence assessment
- Assess whether there is a clear indication for a male external catheter
- Check all management aspects related to incontinence therapy
- Check whether the patient or his caregivers are able to fit and manage the sheath and collection system
- Select the most optimal material (type of male external catheter) for an individual patient
- Select the correct size, fixation method and drainage system
- Inform the patient about the risks associated with using a male external catheter
- Inform about the risk and symptoms of urinary tract infections
- Inform on what to do if there are any problems

9. Abbreviations

IC	Intermittent catheterisation
MEC	Male external catheter
PU	Polyurethane
PVC	Polyvinyl chloride
PVR	Post void residual urine
UTI	Urinary tract infection

10. References

1. BioRelief.com Male External Catheters (MEC) vs. Internal Catheters.
<http://www.biorelief.com/mec.html>
2. Doherty W. Urinary sheaths: assessment, prescription and evaluations. *Br J Community Nurs.* 2001 Jun;6(6):313-6.
3. MHRA Device Bulletin 9601: Latex Sensitisation in the Health Care Setting Medical Devices Agency; April 1996.
http://www.mhra.gov.uk/home/idcplg?IdcService=SS_GET_PAGE&useSecondary=true&ssDocName=CON007367&ssTargetNodeId=572
4. Brosnahan J, Jull A, Tracy C. Types of urethral catheters for management of short-term voiding problems in hospitalised adults. *Cochrane Database Syst Rev.* 2004;(1):CD004013.
<http://www.mrw.interscience.wiley.com/cochrane/clsysrev/articles/CD004013/frame.html>
5. Doherty W, Winder A. The Aquacath hydrophilic coated single-use urinary catheter. *Br J Nurs.* 1998 Nov 26-Dec 9;7(21):1332-6.
6. Pomfret I. Penile sheaths: a guide to selection and fitting, *JCN online*, November 2006, Vol. 20:11.
7. Woodward S. Complications of allergies to latex urinary catheters. *Br J Nurs.* 1997 Jul 24-Aug 13;6(14):786-8, 790, 792-3.
8. Pomfret I. Choosing the right urinary drainage system in incontinence care. *Community Nurse.* 2000 Nov;6(10):29-30, 33.
9. Speechley V, Rosenfield M. *Cancer Information at Your Fingertips.* 3rd ed. London; Class Publishing, 2001.
10. Kennedy I, Grubb A. *Medical Law* 3rd ed. London, Dublin and Edingburgh; Butterworths, 2000, 101.
11. Robinson J. Continence: sizing and fitting a penile sheath. *Br J Community Nurs.* 2006 Oct;11(10):420-7.
12. Guidelines of the German Association for Geriatrics, *Euro J Ger Supplement Vol. 7* (2005) No. 2:1-44, ISSN:1439-1447.
13. Gammack JK. Use and management of chronic urinary catheters in long-term care: much controversy, little consensus. *J Am Med Dir Assoc.* 2002 May-Jun;3(3):162-8.
14. Kinney AB, Blount M. Effect of cranberry juice on urinary pH. *Nurs Res.* 1979 Sep-Oct;28(5):287-90.
15. Asscher AW, Sussman M, Waters WE, Davis RH, Chick S. Urine as a medium for bacterial growth. *Lancet.* 1966 Nov 12;2(7472):1037-41.
http://www.ncbi.nlm.nih.gov/entrez/query.fcgi?cmd=Retrieve&db=pubmed&dopt=Abstract&list_uids=4162501&itool=iconnoabstr
16. Wilson J. Control and prevention of infection in catheter care. *Community Nurse.* 1997 Jun;3(5):39-40.
http://www.ncbi.nlm.nih.gov/entrez/query.fcgi?cmd=Retrieve&db=pubmed&dopt=Abstract&list_uids=9451152&itool=iconnoabstr
17. Pomfret I. Catheter care. *Primary Health Care*, 1999;5:29-37. (Booklet)
18. Simpson L. Improving community catheter management. *Prof Nurse.* 1999 Sep;14(12):831-4.
http://www.ncbi.nlm.nih.gov/entrez/query.fcgi?cmd=Retrieve&db=pubmed&dopt=Abstract&list_uids=10603892&itool=iconabstr

19. Pellowe CM, Pratt RJ, Harper P, Loveday HP, Robinson N, Jones SR, MacRae ED, Mulhall A, Smith GW, Bray J, Carroll A, Chievey Williams S, Colpman D, Cooper L, McInnes E, McQuarrie I, Newey JA, Peters J, Pratelli N, Richardson G, Shah PJ, Silk D, Wheatley C; Guideline Development Group. Evidence-based guidelines for preventing healthcare-associated infections in primary and community care in England. *J Hosp Infect.* 2003 Dec;55 Suppl 2:S2-127.
20. Stelling JD, Hale AM. Protocol for Changing Condom Catheters in Males with Spinal Cord Injury, *SCI Nursing* 1996 Jun;13(2):28-34.
21. Esclarin De Ruz A, Garcia Leoni E, et al. (2000). Epidemiology and risk factors for urinary tract infection in patients with spinal cord injury. *J Urol*;164(4):1285-9.
22. Waites KB, Canupp KC, et al. (1993). Epidemiology and risk factors for urinary tract infection following spinal cord injury. *Arch Phys Med Rehabil*;74(7):691-5.
23. Zimakoff J, Stickler DJ, Pontoppidan B, Larsen SO. (1996). Badder management and urinary tract infections in Danish hospitals, nursing homes, and home care: a national prevalence study. *Infect Control Hosp Epidemiol.* 1996 Apr;17(4):215-21.
24. Sturmman D, O'Grady S, D'mello V. (1989). Management of urinary incontinence: a comparative study in a continuing care facility. *Infect Control Can;Dec* 4(4).
25. Hirsh DD, Fainstein V, et al. (1979). Do condom catheter collecting systems cause urinary tract infection? *Jama*;242(4):340-1.
26. Ouslander JG, Greengold B, Chen S. External catheter use and urinary tract infections among incontinent male nursing home patients. *J Am Geriatr Soc* 1987;35 (12):1063-1070.
27. Leaver RB. Cranberry Juice. *Prof Nurse.* 1996 May;11(8):525-6.
28. Sobota AE. Inhibition of bacterial adherence by cranberry juice: potential use for the treatment of urinary tract infections. *J Urol.* 1984 May;131(5):1013-6.
29. Pomfret IJ. Urinary continence management – penile sheaths *JCN Online Journal.* 1999.
30. Bath J, Fader M, Patterson L. Urinary sheaths and bags making an informed choice. 1999 *Primary Health care*;9(7):17-23.
31. Doherty W. Urinary sheaths: assessment, prescription and evaluation. *Br J Community Nurs.* Volume 6, Issue 2, February 2001;80-85.
32. Brodie A. A guide to the management of one-piece urinary sheaths. *Nursing Times* 2006;102:9,49-51.
33. Pomfret I. Back to basics – Urinary Sheaths, *JCN Online*, October 2003, Volume 17, Issue 10.
34. Udri G, Sauer M. Tutorial for Continence Systems, April 2002, Manfred Sauer Ltd. UK.
35. Pratt RJ, Pellowe CM, Wilson JA, Loveday HP, Harper PJ, Jones SR, McDougall C, Wilcox MH. epic2: National evidence-based guidelines for preventing healthcare-associated infections in NHS hospitals in England. *J Hosp Infect.* 2007 Feb;65 Suppl 1:S1-64.
36. Continence Foundation, 2005 Fact Sheet No.2, www.continence-foundation.org.uk.
37. Newmann D, Fader M, Bliss DZ. Managing Incontinence Using Technology, Devices, and products – Directions for research, *Nursing Research* Nov, Dec. 2004 Vol 53, 6S.
38. Monroy-Torres R, Macias AE. Does cranberry juice have bacteriostatic activity? *Rev Invest Clin.* 2005 May-Jun;57(3):442-6. [Spanish]
http://www.ncbi.nlm.nih.gov/entrez/query.fcgi?cmd=Retrieve&db=pubmed&dopt=Abstract&list_uids=16187705&query_hl=9
39. McMurdo ME, Bissett LY, Price RJ, Phillips G, Crombie IK. Does ingestion of cranberry juice reduce symptomatic urinary tract infections in older people in hospital? A double-blind, placebo-controlled trial. *Age Ageing.* 2005 May;34(3):256-61.
http://www.ncbi.nlm.nih.gov/entrez/query.fcgi?cmd=Retrieve&db=pubmed&dopt=Abstract&list_uids=15863410&query_hl=11

40. Harmon CB, Connolly SM, Larson TR. Condom related allergic contact dermatitis Journal of urology, 1995; April, Vol. 153:1227-1228.
41. Lyder CH, MCCray G., Singh MK. Efficacy of Condom Catheters in Controlling Incontinence Odor. Applied Nursing Research, 1992;November, Vol 5 no 4:186-187.
42. Potter I. Male urinary incontinence-could penile Sheaths be the answer? JCNOnline Journal, Dec 2006.

11. About the authors

Elisabeth Bonns (FI)

Registered nurse, urotherapist, and responsible for urological nursing at the Central Hospital in Vaasa. Elisabeth is a member of the board of Urhot, a Finnish organisation for urological nurses.

Special interests: Through teaching and informational programmes, improving urological nursing care, focusing on the maintenance of quality of life in patients presenting with prostate pathology.

Hanny Cobussen-Boekhorst (NL)

Registered Nurse, Nurse Practitioner continence and urostomy care for adults and children at the department of Urology of the University Medical Centre St Radboud, Nijmegen, The Netherlands. Hanny is a member of the National Continence Nursing Society and active in their conference board. She is also a member of the National Stoma Nursing Society and a member of the ESPU-N (European Society for Paediatric Urology Nurses Group). In 2007 Hanny developed a patient information booklet about clean intermittent catheterisation, including a protocol for nurses, in collaboration with the National Continence Nursing Society.

Hanny Cobussen is a frequent speaker at national and international conferences and is involved in the national continence course for nurses.

Special interests: Urological problems in patients with Multiple Sclerosis (MS) and (children with) Spina Bifida and Extrophia Vesicae, as well as urotherapy in children.

Piet Eelen (BE)

Bachelor in Nursing from the Katholieke Hogeschool Leuven, Belgium – 1981. Special degrees in Nursing Management, Rehabilitation Nursing, Continence Nursing. Piet is an active member of UROBEL (Urological Nurses Belgium) and BVRV (Belgian Association of Rehabilitation Nurses) and a member of the RIMS (Rehabilitation in Multiple Sclerosis) and ICS (International Continence Society).

Special interests: Urological problems in patients with Multiple Sclerosis (MS); frequent speaker at national and international conferences on the topic of MS, urological disturbances and nursing solutions.

Piet Eelen currently works as a head nurse at the rehab-unit for MS patients in Melsbroek, Belgium.

Veronika Geng (DE)

Registered Nurse, Infection Control Practitioner, Coach for Quality in Health Care; Master Degree in Nursing Science and performed clinical studies on the incidence of hospital acquired urinary tract infections. Veronika previously contributed, as a panel member, to guidelines on male external catheters and also produced an instructional videotape on this topic. Special interests: Infection control in rehabilitation in long-term care and rehabilitation facilities and in the management of urinary and fecal incontinence in spinal cord injured persons.

Veronika Geng currently works as a project leader for the Manfred-Sauer-Foundation in Lobbach, Germany.

Christian Seidler (DE)

Trained as a nurse at the BG and University Hospital Bergmannsheil in Bochum from 1993 – 1996. Christian was employed as a nurse at the septic ward of the spinal cord centre in Bochum until 2006, acting as clinical advisor as of 2002 and practical advisor since 2004.

Christian Seidler was engaged by Hollister Incorporated (Munich) as Clinical Advisor for Continence Care until November 2007 and is currently working at the tetraplegic ward (only ventilated patients) of the spinal cord centre at the BGU Hamburg (Boberg).

The Writing Group realises that procedures will vary between principalities and even between medical facilities. The Writing Group is aware that there may be other correct methods and products available that would also accomplish the task. However, one of the aims of the EAUN is to “standardise nursing practices.” The materials/procedures recommended in this booklet are based on what the Group believes to be the basic requirements for successful male external catheterisation.

If you have questions or comments regarding this publication, please contact:

The EAU Central Office – EAUN Division
P.O. Box 30016
6803 AA ARNHEM
The Netherlands

E-mail: eaun@uroweb.org

You can also visit the EAUN website: www.eaun.uroweb.org.

Publication of this booklet was made possible by an
unrestricted educational grant from Hollister



We are very grateful to BioDerm, Largo, FL (USA), Hollister Europe Ltd, Munich (DE), Coloplast, Hamburg (DE), Manfred Sauer Continence, Lobbach (DE) and Allegro Medical, AZ (USA) for their assistance with the illustrations included in this publication.

This booklet has been edited for the European Association of Urology Nurses under the auspices of the EAUN Board and the EAU Professions Allied to Urology Office.

2008

ISBN 978 90 70244 80 4
Printed by Drukkerij Gelderland
Arnhem - The Netherlands

© EAU. No part of this publication may be reproduced, stored in a retrieval system, or transmitted by any means, electronic, mechanical or photocopying without written permission from the copyright holder.